

S3000E

Open cooling towers



Key benefits

- Extreme low sound levels, outperforming counterflow axial fan units
- Unmatched energy savings, with less than 2 years payback
- Low maintenance and easy inspection, 25% reduction in annual maintenance costs



S3000E characteristics

Cross flow, axial fan, induced draft

Capacity range

18 - 285 l/s

Water distribution

Gravity, with weir dams for variable flow

Maximum entering water temperature

55°C standard fill
60°C with alternative fill

Typical applications

- Medium to large HVAC and industrial applications
- Replacement of field erected towers



Extreme low sound levels

- A choice of various fan types such as low noise axial fans and [Whisper Quiet fans](#) for **minimal surrounding noise**
- [BACross fill](#) smoothly guides the water all the way into the basin **without water splash noise**.
- Try our XES3000E line with smaller motors for extremely low noise levels.
- Factory designed, tested and rated [sound attenuation](#) is available on air inlet and discharge to cut operation noise even further.

Unmatched energy savings

- **Evaporative cooling** for system-wide energy saving at lower operating temperatures.
- **Axial fan** uses **half the energy** of similar centrifugal fan units.
- **Save pump kW!** Less pump head for this gravity water distribution system. In periods of reduced load, **weir dams** close off partly the hot water basin **saving pump energy**.
- [BACross fill](#) – factory-configured for maximum water/air contact and low air pressure drop for optimal cooling tower efficiency with limited energy consumption.
- **High efficiency fan motors**
- [XES3000E](#) line with smaller motors to reduce electricity consumption for the same cooling capacity.

Low maintenance and easy inspection

- The S3000E has a **spacious plenum** (internal area) and **easy access** to inspect and maintain safely the unit interior components. **Unrivalled comfort, while standing** inside.
- Upgrade the unit interior with **ladder and platform** for quick and safe access to all unit components.
- **Access via large hinged door to optional internal walkway:** no basin draining needed for unit interior or fill pack inspection.
- You can inspect and clean easily the core of the [BACross fill](#) **sheet by sheet without dismantling**. BACross design reduces fouling. Optional **telescopic supports** for easy replacement of the sheets.
- The fill includes integrated **drift eliminators** tested and certified by Eurovent.
- Inspection of **water distribution system** (hot water basin and nozzles) possible outside the unit, **during operation**.
- Optional [distribution basin covers](#) prevent debris collecting in the unit.
- Self-cleaning cold water basin and fill above **sloped basin** to flush out dirt and debris.
- **Fans** are easily accessible from the in- and outside
- Optional [clean out port](#) **helps remove** silt and sludge from the cooling tower basin.
- Removable **suction strainer** anti-vortex hood.
- Optional [sump sweeper piping](#) **prevents sediment collecting in the cold water basin**.
- Various corrosion-resistant materials, including the unique [Baltibond hybrid coating](#) for guaranteed long service life.

Unmatched hygiene control



- Easy-clean and easy-inspect S3000E towers **reduce hygiene risks** from bacteria (eg Legionella) or biofilm inside.
- Self-cleaning cold water basin and fill above **sloped basin** to flush out dirt and debris.
- [BACross fill](#) for reduced fouling and easy sheet by sheet cleaning without dismantling.
- The fill includes integrated **drift eliminators** tested and certified by Eurovent.
- **Combined inlet shields** block sunlight to prevent biological growth in the tower, filter the air and stop water splashing outside.
- Optional [distribution basin covers](#) prevent debris collecting in the unit.
- Optional [clean out port](#) **helps remove** silt and sludge from the cooling tower basin.
- Optional [sump sweeper piping](#) **prevents sediment collecting in the cold water basin.**

Year round reliable operation

- Top rated thermal performance - meets **any flow and temperature needs.**
- The thermal performance of S3000E cooling towers is tested and [certified by Eurovent.](#)
- Patented [BACross](#) sheet fill with **maximum air and water contact** gives unbeatable heat transfer performance.
- Various **corrosion-resistant** materials, including the unique [Baltibond hybrid coating](#) and FRP casing panels for guaranteed long service life.
- Optional [gear-drive system](#) for more efficiency and less maintenance.

Want to use the S3000E cooling towers to cool your process water? Contact your local BAC representative.

Downloads

- [S3000E compilation pdf \(EN\)](#)
- [M - S3000E \(EN\)](#)
- [R - S3000E \(EN\)](#)

S3000E

Open cooling towers

Principle of operation

Warm process **water (1)** from the heat source enters the **water distribution system (2)** at the top of the cooling tower on both sides where it is distributed over the **fill** or heat transfer media **(3)**. At the same time the **axial fan (4)**, located at the top of the unit, draws the **air (5)** from the sides of the unit over the fill. While the warm process water contacts the cold air the latter heats up and part of the process water is evaporated which removes the heat from the remaining water. The **sloping sump (6)** or basin collects the cooled water after which it returns to the **heat source of the process (7)**. The warm saturated **air (8)** first passes through the **drift eliminators (9)**, which remove water droplets from the air, and then exits the tower at the top.

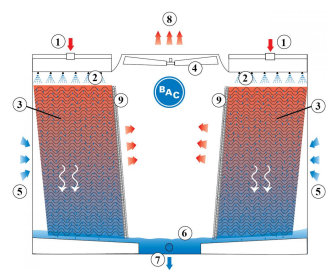

You want to use the S3000E cooling tower to cool your process water? Contact your local [BAC representative](#).



S3000E

Open cooling towers

Construction details

1. Material options

- Heavy-gauge hot-dip galvanized steel is used for external unit steel panels and structural elements featuring [Baltiplus Corrosion Protection](#).
- For casing panels we use UV resistant **fiberglass** reinforced polyester. The unique [Baltibond hybrid coating](#) is an optional extra. A hybrid polymer coating for longer service life, applied pre-assembly to all hot-dip galvanized steel components of the unit.
- [Optional stainless steel](#) panels and structural elements of type 304 or 316 for extreme applications.
- Or the economical alternative: a **water-contact stainless steel cold (and hot) water basin**. Its key components and the basin itself are stainless steel. The rest is protected with the **Baltibond hybrid coating**.

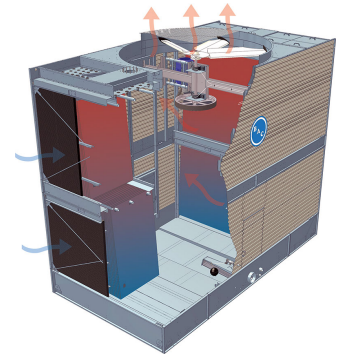

2. Heat transfer media

- Our heat transfer media is patented [BACross fill](#) with integrated **drift eliminators** certified by Eurovent. Thermal cooling tower performance was shown in comprehensive [lab thermal performance tests](#) and offers you unrivalled system efficiency.
- Patented BACross fill **eliminates water splash-out** and allows freeze free winter operation. The fill pack includes individual **sheets**. Sheets are easy to inspect and clean inside the tower without dismantling, eliminating the need for frequent fill replacement. Optional telescopic support for easy fill replacement.
- In self-extinguishing **plastic**, which will not rot, decay or decompose.
- For operation above 55°C, try our **optional high temperature fill**, usable with intake water up to 60°C.



3. Air movement system

- S3000E **fan system** features two corrosion resistant sheaves, belt and motor. Together with the heavy duty fan shaft bearings and the BAC **Impervix** motor, this guarantees optimal and year-round operational efficiency.
- **Fan(s)** in corrosion resistant aluminum, encased in fan cylinder with removable fan guard. To reduce noise even further, choose for a low noise or [Whisper Quiet fan](#) with minimal impact on thermal performance.
- Easy removable UV-resistant plastic **combined inlet shields** at air inlet. Sunlight block to prevent biological growth in tower, air filter and water splash-out stop.



4. Water distribution system

These consist of:

- **Low pump gravity water distribution basin** with wide non-clog plastic nozzles for uniform water distribution. You can easily clean and flush both nozzles and basin.
- **Weir dams** in the hot water basin for variable flow. These close off partly the hot water basin in periods of reduced load, resulting in **up to 50% power savings** on process pump and ensuring **freeze free operation**.
- A **sloped cold water basin** with:
 - large hinged and inward swinging **access** door
 - anti-vortexing **strainers** and **make up** both easily accessible from inside the unit.
 - optional **internal walkway** for easy access to the interior of the unit.

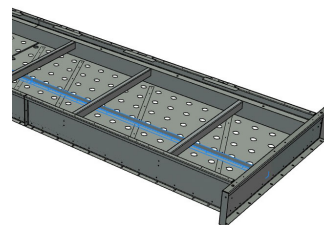

Need more information? Contact your local [BAC representative](#).

S3000E

Open cooling towers

Options and accessories

Below is a listing of the main S3000E options and accessories. If your required option or accessory is not listed, look no further than your [local BAC representative](#).

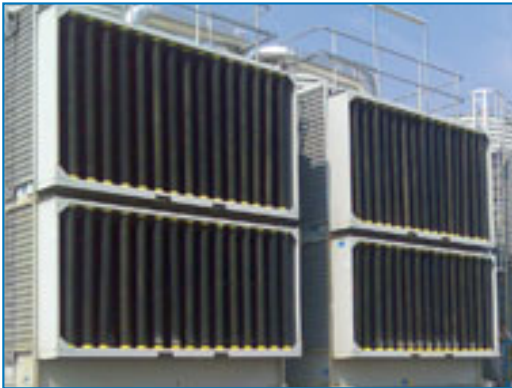

Sound attenuation

Reducing noise at air **intake and discharge points** brings us closer to silent cooling equipment.

[Read more](#)



Whisper Quiet fan

Reduce fan noise even more with **very low sound factory-tested fans**. [Read more](#)



Gear drive system with close coupled motor

A close-coupled gear box for **more efficiency** and **less maintenance**. [Read more](#)



Gear drive system with externally mounted motor

A gear box with an external motor outside the air stream helps **improve efficiency** and **ease of maintenance**. [Read more](#)



Velocity recovery stacks

To **boost capacity in confined spaces**, select a velocity recovery stack on top of the fan cylinder. [Read more](#)



Telescopic fill support

Telescopic support facilitate **fill replacement** on-site. [Read more](#)



Internal service platform

An internal platform helping you **access the unit top inside** and safely inspect your cooling towers. [Read more](#)



Internal walkway

An internal walkway for **easy access to the unit water basin**. [Read more](#)



Ladder, safety cage and handrail

A ladder, safety cage and handrails **all facilitate access to the top of the unit** and safe inspection of your cooling tower. [Read more](#)



Basin heater package

Thanks to our factory-installed heaters, the water stays at 4°C and **never freezes**, even during equipments downtime and however cold it gets outside. [Read more](#)



Remote sump connection

The best way to **prevent a sump freezing** is to use the auxiliary remote variety within a heated area. Shutting off the circulating pump allows all the water in the water distribution, as well as that in suspension and the sump to drain freely to the auxiliary sump. [Read more](#)



Extended lubrication lines

Extended lubrication lines with easily accessible grease fittings can be used **to lubricate** fan shaft bearings. [Read more.](#)



Electric water level control package

For perfectly precise water level control, replace the standard mechanical valve with our electrical water level controller. [Read more](#)



Mechanical equipment removal system

This **helps** you **remove or install** fan motors or gearboxes. [Read more](#)



Vibration cut out switch

When excessive vibration occurs, this switch shuts down the fan, ensuring your cooling equipment **operates safely.** [Read more](#)



Water treatment equipment

Devices to control water treatment are needed to ensure proper **cooling tower water care**. Not only does this help protect the components and fill pack, controlling corrosion, scaling and fouling, it also avoids the proliferation of harmful bacteria, including **legionella**, in the recirculating water. [Read more](#)



Sump sweeper piping

Sump sweeper piping **prevents sediment collecting in the cold water basin** of the unit. A complete piping system, including nozzles, is installed in the basin of the tower **for connection to side stream filtration** equipment. [Read more](#)



Filter

Separators and media filters efficiently **remove suspended solids** in the recirculating water, reducing system cleaning costs and optimizing water treatment results. Filtration helps you keep the recirculating water clean. [Read more](#)



Clean out port

Clean out port **makes it easy to eliminate silt and sludge** from the cooling tower basin when cleaning and flushing the sump. [Read more](#)

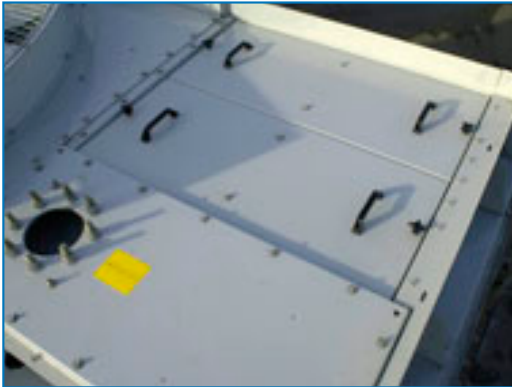

Distribution basin covers

Distribution basin covers on unit tops **prevent debris collecting** in unit water distribution basins. [Read more](#)

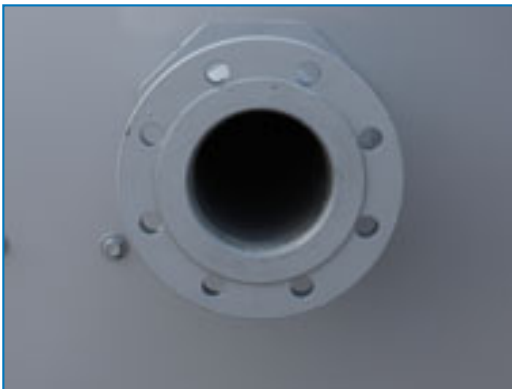

Flanges

Flanges facilitate **pipng connections** on-site. [Read more](#)



S3000E



Open cooling towers

Engineering data

REMARK: Do not use for construction. Refer to factory certified dimensions & weights. This page includes data current at time of publication, which should be reconfirmed at the time of purchase. In the interest of product improvement, specifications, weights and dimensions are subject to change without notice.

General notes

1. Operating weight is for tower with the water level in the cold water basin at overflow. If a lower operating weight is needed to meet design requirements, your local BAC Balticare representative can provide additional assistance.
2. Heights are for units with gear drive, except for models with motors up to and including 18,5 kW which are only available with belt-drive.
3. Models with motors of 22 to 55 kW are shipped an optional gear drive and may have heights up to 190 mm lower than shown.
4. Models with optional Whisper Quiet fan may have heights up to 1000 mm greater than shown.
5. Models with an optional Velocity Recovery Stack can be up to 1500 mm higher
6. Intake attenuators are shipped installed for single cell units. For 2 or more cells, consult factory.
7. Models 1222-10 thru 1222-14 and 1424-12 thru 1424-14 ship in two sections per cell. Top section heights are for models 1222-10 thru 1222-13 and 1424-12 thru 1424-13, 2838 mm. For models 1222-14 and 1424-14, 3245 mm.

Last update: 31 July 2016

S3E 8518, 1020-1424

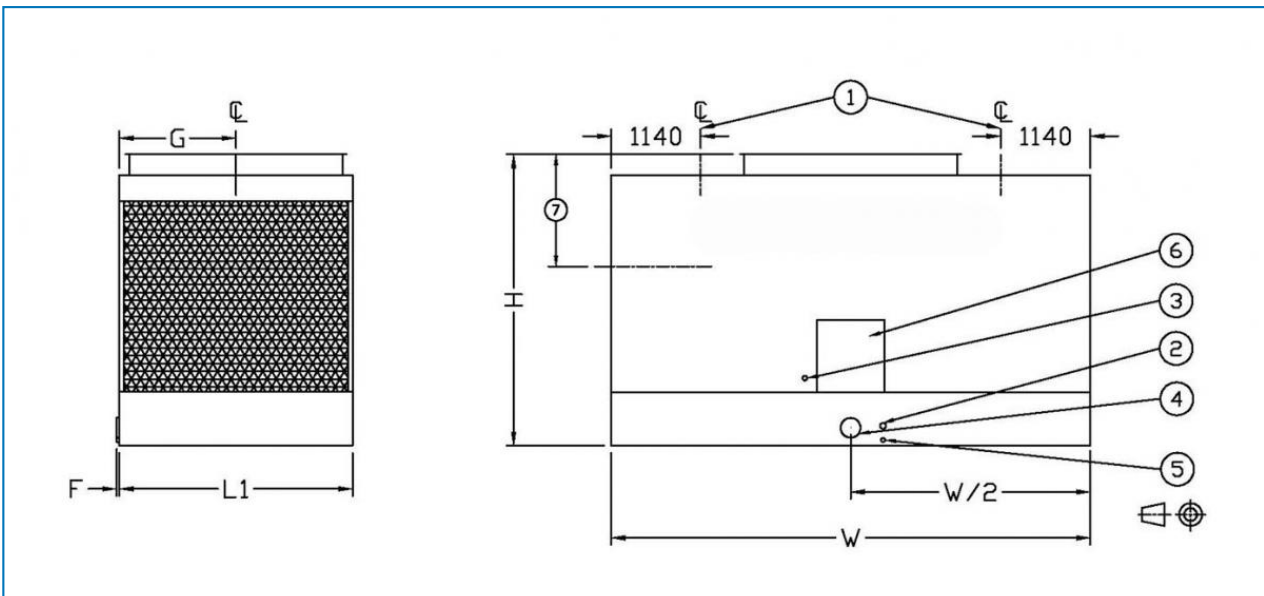

1. Water in; 2. Overflow ND80; 3. Make up; 4. Water out; 5. Drain ND50; 6. Access door.



Model	Weights (kg)			Dimensions (mm)			Air Flow (m ³ /s)	Fan Motor (kW)	Fluid Inlet ND (mm)	Fluid Outlet ND (mm)	Make Up ND (mm)
	Oper. Weight (kg)	Ship. Weight(kg)	Heaviest Section (kg)	L	W	H					
S3E 8 518-05 L/H	6878	3639	3639	2585	5500	2840	36.5	(1x) 11.0	(2x) 150	(1x) 200	(1x) 25
S3E 8 518-05 M/H	6905	3666	3666	2585	5500	2840	39.9	(1x) 15.0	(2x) 150	(1x) 200	(1x) 25
S3E 8 518-06 L/H	7271	3789	3789	2585	5500	3247	39.7	(1x) 11.0	(2x) 150	(1x) 200	(1x) 25
S3E 8 518-06 M/H	7280	3798	3798	2585	5500	3247	43.3	(1x) 15.0	(2x) 150	(1x) 200	(1x) 25
S3E 8 518-06 N/H	7293	3812	3812	2585	5500	3247	46.4	(1x) 18.5	(2x) 150	(1x) 200	(1x) 25
S3E 8 518-06 O/H	7316	3834	3834	2585	5500	3437	48.4	(1x) 22.0	(2x) 150	(1x) 200	(1x) 25
S3E 1 020-06 M/H	8681	4327	4327	2980	6110	3247	46.2	(1x) 15.0	(2x) 150	(1x) 200	(1x) 40
S3E 1 020-06 N/H	8745	4391	4391	2980	6110	3247	49.4	(1x) 18.5	(2x) 150	(1x) 200	(1x) 40
S3E 1 020-06 O/H	8767	4413	4413	2980	6110	3437	52.2	(1x) 22.0	(2x) 150	(1x) 200	(1x) 40
S3E 1 020-07 M/H	9152	4483	4483	2980	6110	3653	49.8	(1x) 15.0	(2x) 150	(1x) 250	(1x) 40
S3E 1 020-07 N/H	9216	4547	4547	2980	6110	3653	53.3	(1x) 18.5	(2x) 150	(1x) 250	(1x) 40
S3E 1 020-07 O/H	9239	4569	4569	2980	6110	3843	56.3	(1x) 22.0	(2x) 150	(1x) 250	(1x) 40
S3E 1 020-07 P/H	9311	4642	4642	2980	6110	3843	61.4	(1x) 30.0	(2x) 150	(1x) 250	(1x) 40
S3E 1 222-06 M/H	10730	5161	5161	3600	6566	3437	53.1	(1x) 15.0	(2x) 200	(1x) 250	(1x) 40
S3E 1 222-06 N/H	10793	5224	5224	3600	6566	3437	56.8	(1x) 18.5	(2x) 200	(1x) 250	(1x) 40
S3E 1 222-06 O/H	10816	5247	5247	3600	6566	3437	60.0	(1x) 22.0	(2x) 200	(1x) 250	(1x) 40
S3E 1 222-07 N/H	11404	5493	5493	3600	6566	3843	61.3	(1x) 18.5	(2x) 200	(1x) 250	(1x) 40
S3E 1 222-07 O/H	11426	5516	5516	3600	6566	3843	64.7	(1x) 22.0	(2x) 200	(1x) 250	(1x) 40
S3E 1	11499	5589	5589	3600	6566	3843	70.6	(1x)	(2x)	(1x)	(1x) 40



222-07 P/H								30.0	200	250	
S3E 1 222-07 Q/H	11504	5593	5593	3600	6566	3843	75.4	(1x) 37.0	(2x) 200	(1x) 250	(1x) 40
S3E 1 222-07 R/H	11848	5938	5938	3600	6566	3843	79.7	(1x) 45.0	(2x) 200	(1x) 250	(1x) 40
S3E 1 222-10 P/H	15196	6953	4083	3600	6566	5110	84.9	(1x) 30.0	(2x) 200	(1x) 300	(1x) 40
S3E 1 222-10 Q/H	15268	7025	4156	3600	6566	5110	90.5	(1x) 37.0	(2x) 200	(1x) 300	(1x) 40
S3E 1 222-10 R/H	15273	7030	4161	3600	6566	5110	95.5	(1x) 45.0	(2x) 200	(1x) 300	(1x) 40
S3E 1 222-10 S/H	15708	7465	4596	3600	6566	5110	101.8	(1x) 55.0	(2x) 200	(1x) 300	(1x) 40
S3E 1 222-12 P/H	16439	7373	4133	3600	6566	5923	90.1	(1x) 30.0	(2x) 200	(1x) 300	(1x) 40
S3E 1 222-12 Q/H	16467	7400	4161	3600	6566	5923	96.0	(1x) 37.0	(2x) 200	(1x) 300	(1x) 40
S3E 1 222-12 R/H	16562	7495	4256	3600	6566	5923	101.2	(1x) 45.0	(2x) 200	(1x) 300	(1x) 40
S3E 1 222-12 S/H	16997	7931	4691	3600	6566	5923	107.9	(1x) 55.0	(2x) 200	(1x) 300	(1x) 40
S3E 1 222-13 P/H	16857	7583	4133	3600	6566	6330	92.6	(1x) 30.0	(2x) 200	(1x) 300	(1x) 40
S3E 1 222-13 Q/H	16885	7610	4161	3600	6566	6330	98.7	(1x) 37.0	(2x) 200	(1x) 300	(1x) 40
S3E 1 222-13 R/H	16980	7705	4256	3600	6566	6330	104.0	(1x) 45.0	(2x) 200	(1x) 300	(1x) 40
S3E 1 222-13 S/H	17016	7742	4292	3600	6566	6330	110.9	(1x) 55.0	(2x) 200	(1x) 300	(1x) 40
S3E 1 222-14 P/H	17049	7775	4353	3600	6566	6737	95.8	(1x) 30.0	(2x) 200	(1x) 300	(1x) 40
S3E 1 222-14 Q/H	17077	7802	4380	3600	6566	6737	102.1	(1x) 37.0	(2x) 200	(1x) 300	(1x) 40
S3E 1 222-14 R/H	17149	7875	4452	3600	6566	6737	107.6	(1x) 45.0	(2x) 200	(1x) 300	(1x) 40
S3E 1 222-14 S/H	17186	7911	4489	3600	6566	6737	115.1	(1x) 55.0	(2x) 200	(1x) 300	(1x) 40
S3E 1 222-14 T/H	18056	8782	4983	3600	6566	6737	124.7	(1x) 75.0	(2x) 200	(1x) 300	(1x) 40
S3E 1 424-07	15647	7466	7466	4245	7328	3845	72.6	(1x) 22.0	(2x) 200	(1x) 300	(1x) 40



O/H											
S3E 1 424-07 P/H	15720	7538	7538	4245	7328	3845	79.2	(1x) 30.0	(2x) 200	(1x) 300	(1x) 40
S3E 1 424-07 Q/H	15724	7543	7543	4245	7328	3845	84.6	(1x) 37.0	(2x) 200	(1x) 300	(1x) 40
S3E 1 424-07 R/H	15729	7547	7547	4245	7328	3845	89.4	(1x) 45.0	(2x) 200	(1x) 300	(1x) 40
S3E 1 424-12 Q/H	20173	9814	5395	4245	7328	5923	110.1	(1x) 37.0	(2x) 250	(1x) 350	(1x) 50
S3E 1 424-12 R/H	20245	9887	5468	4245	7328	5923	115.9	(1x) 45.0	(2x) 250	(1x) 350	(1x) 50
S3E 1 424-12 S/H	20268	9909	5490	4245	7328	5923	123.4	(1x) 55.0	(2x) 250	(1x) 350	(1x) 50
S3E 1 424-12 T/H	21139	10780	5985	4245	7328	5923	132.6	(1x) 75.0	(2x) 250	(1x) 350	(1x) 50
S3E 1 424-13 Q/H	20799	9991	5395	4245	7328	6330	113.5	(1x) 37.0	(2x) 250	(1x) 350	(1x) 50
S3E 1 424-13 R/H	20871	10064	5468	4245	7328	6330	119.5	(1x) 45.0	(2x) 250	(1x) 350	(1x) 50
S3E 1 424-13 S/H	20894	10086	5490	4245	7328	6330	127.2	(1x) 55.0	(2x) 250	(1x) 350	(1x) 50
S3E 1 424-13 T/H	21765	10957	5985	4245	7328	6330	136.6	(1x) 75.0	(2x) 250	(1x) 350	(1x) 50
S3E 1 424-14 Q/H	21517	10168	5735	4245	7328	6737	117.8	(1x) 37.0	(2x) 250	(1x) 350	(1x) 50
S3E 1 424-14 R/H	21590	10240	5808	4245	7328	6737	124.0	(1x) 45.0	(2x) 250	(1x) 350	(1x) 50
S3E 1 424-14 S/H	21612	10263	5831	4245	7328	6737	132.5	(1x) 55.0	(2x) 250	(1x) 350	(1x) 50
S3E 1 424-14 T/H	22483	11134	6325	4245	7328	6737	141.7	(1x) 75.0	(2x) 250	(1x) 350	(1x) 50

XES3000E

Open cooling towers

Engineering data

REMARK: Do not use for construction. Refer to factory certified dimensions & weights. This page includes data current at time of publication, which should be reconfirmed at the time of purchase. In the interest of product improvement, specifications, weights and dimensions are subject to change without notice.

General notes

1. Operating weight is for tower with the water level in the cold water basin at overflow. If a lower operating weight is needed to meet design requirements, your local BAC Balticare representative can provide additional assistance.
2. Heights are for units with gear drive, except for models with motors up to and including 18,5 kW which are only available with belt-drive.
3. Models with motors of 22 to 55 kW are shipped an optional gear drive and may have heights up to 190 mm lower than shown.
4. Models with optional Whisper Quiet fan may have heights up to 1000 mm greater than shown.
5. Models with an optional Velocity Recovery Stack can be up to 1500 mm higher
6. Intake attenuators are shipped installed for single cell units. For 2 or more cells, consult factory.
7. Models 1222-10 thru 1222-14 and 1424-12 thru 1424-14 ship in two sections per cell. Top section heights are for models 1222-10 thru 1222-13 and 1424-12 thru 1424-13, 2838 mm. For models 1222-14 and 1424-14, 3245 mm.

Last update: 31 July 2016

XES3E 8518, 1020-1424

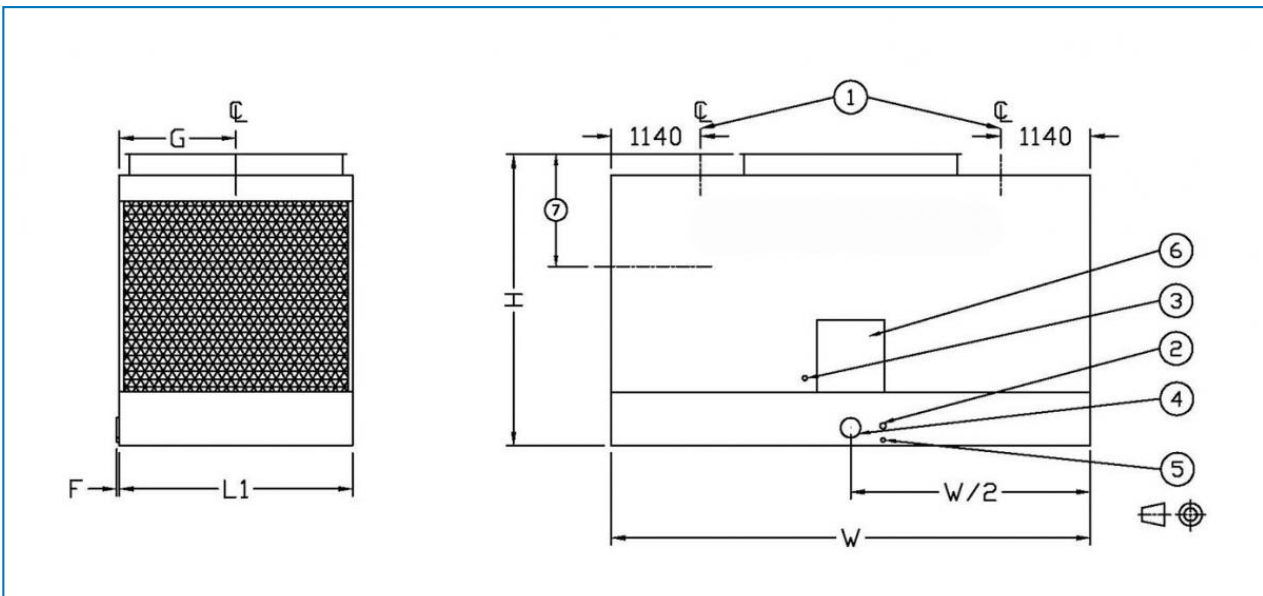

1. Water in; 2. Overflow ND80; 3. Make up; 4. Water out; 5. Drain ND50; 6. Access door.



Model	Weights (kg)			Dimensions (mm)			Air Flow (m³/s)	Fan Motor (kW)	Fluid Inlet ND (mm)	Fluid Outlet ND (mm)	Make Up ND (mm)
	Oper. Weight (kg)	Ship. Weight(kg)	Heaviest Section (kg)	L	W	H					
XES3E 8518-0 5J/H	6706	3083	3083	2585	5500	2840	28.8	(1x) 5.5	(2x) 150	(1x) 200	(1x) 25
XES3E 8518-0 5K/H	6706	3083	3083	2585	5500	2840	31.6	(1x) 7.5	(2x) 150	(1x) 200	(1x) 25
XES3E 8518-0 5G/H	6830	3385	3385	2585	5500	2840	21.7	(1x) 2.2	(2x) 150	(1x) 200	(1x) 25
XES3E 8518-0 5H/H	6840	3390	3390	2585	5500	2840	25.4	(1x) 4.0	(2x) 150	(1x) 200	(1x) 25
XES3E 8518-0 6J/H	7151	3296	3296	2585	5500	3247	31.5	(1x) 5.5	(2x) 150	(1x) 200	(1x) 25
XES3E 8518-0 6K/H	7151	3296	3296	2585	5500	3247	34.4	(1x) 7.5	(2x) 150	(1x) 200	(1x) 25
XES3E 8518-0 6G/H	7195	3505	3505	2585	5500	3247	23.7	(1x) 2.2	(2x) 150	(1x) 200	(1x) 25
XES3E 8518-0 6H/H	7205	3510	3510	2585	5500	3247	27.7	(1x) 4.0	(2x) 150	(1x) 200	(1x) 25
XES3E 1020-0 6J/H	8435	3823	3823	2980	6110	3247	33.5	(1x) 5.5	(2x) 150	(1x) 200	(1x) 40
XES3E 1020-0 6K/H	8435	3823	3823	2980	6110	3247	36.6	(1x) 7.5	(2x) 150	(1x) 200	(1x) 40
XES3E 1020-0 6L/H	8435	3823	3823	2980	6110	3247	41.5	(1x) 11.0	(2x) 150	(1x) 200	(1x) 40
XES3E 1020-0 6G/H	8490	4130	4130	2980	6110	3247	25.3	(1x) 2.2	(2x) 150	(1x) 200	(1x) 40
XES3E 1020-0 6H/H	8495	4135	4135	2980	6110	3247	29.6	(1x) 4.0	(2x) 150	(1x) 200	(1x) 40
XES3E 1020-0 7K/H	8844	3968	3968	2980	6110	3653	39.6	(1x) 7.5	(2x) 150	(1x) 250	(1x) 40
XES3E 1020-0 7L/H	8844	3968	3968	2980	6110	3653	44.8	(1x) 11.0	(2x) 150	(1x) 250	(1x) 40
XES3E 1020-0 7G/H	8925	4355	4355	2980	6110	3653	27.3	(1x) 2.2	(2x) 150	(1x) 250	(1x) 40
XES3E 1020-0 7H/H	8930	4365	4365	2980	6110	3653	32.0	(1x) 4.0	(2x) 150	(1x) 250	(1x) 40
XES3E 1020-0 7J/H	8985	4420	4420	2980	6110	3653	36.3	(1x) 5.5	(2x) 150	(1x) 250	(1x) 40
XES3E	10160	4790	4790	3600	6566	3247	33.9	(1x)	(2x)	(1x)	(1x) 40



1222-0 6H/H								4.0	200	250	
XES3E 1222-0 6J/H	10215	4845	4845	3600	6566	3247	38.5	(1x) 5.5	(2x) 200	(1x) 250	(1x) 40
XES3E 1222-0 6K/H	10483	4626	4626	3600	6566	3247	42.0	(1x) 7.5	(2x) 200	(1x) 250	(1x) 40
XES3E 1222-0 6L/H	10483	4626	4626	3600	6566	3247	47.6	(1x) 11.0	(2x) 200	(1x) 250	(1x) 40
XES3E 1222-0 7J/H	11300	5110	5110	3600	6566	3653	41.6	(1x) 5.5	(2x) 200	(1x) 250	(1x) 40
XES3E 1222-0 7K/H	11305	5110	5110	3600	6566	3653	45.5	(1x) 7.5	(2x) 200	(1x) 250	(1x) 40
XES3E 1222-0 7L/H	11663	4903	4903	3600	6566	3653	51.5	(1x) 11.0	(2x) 200	(1x) 250	(1x) 40
XES3E 1222-0 7M/H	11663	4903	4903	3600	6566	3653	56.2	(1x) 15.0	(2x) 200	(1x) 250	(1x) 40
XES3E 1222-1 0K/H	13795	6420	3680	3600	6566	4920	55.5	(1x) 7.5	(2x) 200	(1x) 300	(1x) 40
XES3E 1222-1 0L/H	13840	6470	3730	3600	6566	4920	62.6	(1x) 11.0	(2x) 200	(1x) 300	(1x) 40
XES3E 1222-1 0M/H	13840	6470	3730	3600	6566	4920	68.2	(1x) 15.0	(2x) 200	(1x) 300	(1x) 40
XES3E 1222-1 0N/H	14555	6251	3959	3600	6566	4920	72.8	(1x) 18.5	(2x) 200	(1x) 300	(1x) 40
XES3E 1222-1 0O/H	14555	6251	3959	3600	6566	5110	76.7	(1x) 22.0	(2x) 200	(1x) 300	(1x) 40
XES3E 1222-1 2K/H	15175	6855	3775	3600	6566	5733	59.1	(1x) 7.5	(2x) 200	(1x) 300	(1x) 40
XES3E 1222-1 2L/H	15225	6905	3825	3600	6566	5733	66.6	(1x) 11.0	(2x) 200	(1x) 300	(1x) 40
XES3E 1222-1 2M/H	15225	6905	3825	3600	6566	5733	72.5	(1x) 15.0	(2x) 200	(1x) 300	(1x) 40
XES3E 1222-1 2N/H	15225	6905	3825	3600	6566	5733	77.3	(1x) 18.5	(2x) 200	(1x) 300	(1x) 40
XES3E 1222-1 2O/H	15904	6583	3995	3600	6566	5923	81.5	(1x) 22.0	(2x) 200	(1x) 300	(1x) 40
XES3E 1222-1 3K/H	15750	6960	3685	3600	6566	6370	60.8	(1x) 7.5	(2x) 200	(1x) 300	(1x) 40
XES3E 1222-1 3L/H	15780	6990	3720	3600	6566	6370	68.6	(1x) 11.0	(2x) 200	(1x) 300	(1x) 40
XES3E 1222-1	15790	7000	3725	3600	6566	6370	74.6	(1x) 15.0	(2x) 200	(1x) 300	(1x) 40



3M/H											
XES3E 1222-1 3N/H	15855	7065	3790	3600	6566	6370	79.6	(1x) 18.5	(2x) 200	(1x) 300	(1x) 40
XES3E 1222-1 3O/H	15875	7085	3815	3600	6566	6560	83.9	(1x) 22.0	(2x) 200	(1x) 300	(1x) 40
XES3E 1222-1 4L/H	16315	7175	3925	3600	6566	6547	71.0	(1x) 11.0	(2x) 200	(1x) 300	(1x) 40
XES3E 1222-1 4M/H	16315	7175	3925	3600	6566	6547	77.2	(1x) 15.0	(2x) 200	(1x) 300	(1x) 40
XES3E 1222-1 4N/H	16315	7175	3925	3600	6566	6547	82.4	(1x) 18.5	(2x) 200	(1x) 300	(1x) 40
XES3E 1222-1 4O/H	16315	7175	3925	3600	6566	6737	86.8	(1x) 22.0	(2x) 200	(1x) 300	(1x) 40
XES3E 1424-0 7M/H	13756	5480	5480	4245	7328	3655	63.1	(1x) 15.0	(2x) 200	(1x) 300	(1x) 40
XES3E 1424-0 7N/H	13756	5480	5480	4245	7328	3655	67.5	(1x) 18.5	(2x) 200	(1x) 300	(1x) 40
XES3E 1424-0 7J/H	14865	7035	7035	4245	7328	3655	46.7	(1x) 5.5	(2x) 200	(1x) 300	(1x) 40
XES3E 1424-0 7K/H	14870	7040	7040	4245	7328	3655	51.1	(1x) 7.5	(2x) 200	(1x) 300	(1x) 40
XES3E 1424-0 7L/H	14920	7090	7090	4245	7328	3655	57.8	(1x) 11.0	(2x) 200	(1x) 300	(1x) 40
XES3E 1424-1 2P/H	18746	7540	4644	4245	7328	5923	101.7	(1x) 30.0	(2x) 250	(1x) 350	(1x) 50
XES3E 1424-1 2L/H	19265	9165	4895	4245	7328	5733	76.8	(1x) 11.0	(2x) 250	(1x) 350	(1x) 50
XES3E 1424-1 2M/H	19265	9165	4895	4245	7328	5733	83.5	(1x) 15.0	(2x) 250	(1x) 350	(1x) 50
XES3E 1424-1 2N/H	19265	9165	4895	4245	7328	5733	89.0	(1x) 18.5	(2x) 250	(1x) 350	(1x) 50
XES3E 1424-1 2O/H	19265	9165	4895	4245	7328	5923	93.7	(1x) 22.0	(2x) 250	(1x) 350	(1x) 50
XES3E 1424-1 3L/H	19885	9335	4910	4245	7328	6370	79.4	(1x) 11.0	(2x) 250	(1x) 350	(1x) 50
XES3E 1424-1 3M/H	19895	9345	4915	4245	7328	6370	86.2	(1x) 15.0	(2x) 250	(1x) 350	(1x) 50
XES3E 1424-1 3N/H	19960	9405	4980	4245	7328	6370	91.9	(1x) 18.5	(2x) 250	(1x) 350	(1x) 50
XES3E 1424-1 3O/H	19980	9430	5005	4245	7328	6560	96.7	(1x) 22.0	(2x) 250	(1x) 350	(1x) 50



XES3E 1424-1 3P/H	20045	9495	5065	4245	7328	6560	104.9	(1x) 30.0	(2x) 250	(1x) 350	(1x) 50
XES3E 1424-1 4M/H	20485	9485	5225	4245	7328	6547	89.6	(1x) 15.0	(2x) 250	(1x) 350	(1x) 50
XES3E 1424-1 4N/H	20485	9485	5225	4245	7328	6547	95.4	(1x) 18.5	(2x) 250	(1x) 350	(1x) 50
XES3E 1424-1 4O/H	20485	9485	5225	4245	7328	6737	100.5	(1x) 22.0	(2x) 250	(1x) 350	(1x) 50
XES3E 1424-1 4P/H	20640	9640	5375	4245	7328	6737	109.0	(1x) 30.0	(2x) 250	(1x) 350	(1x) 50